

FRONT VIEW
SCALE 1 : 2

SIDE VIEW
SCALE 1 : 2

NOTE :
- ALL DIMENSION ARE IN MILLIMETERS

5	STOPPER	-	-	2	
4	รางปิดกั้น	-	ALUMINIUM	1	
3	TERMINAL BLOCK	4P 25A	-	1	
2	CIRCUIT BREAKER	1P 10A IC 6KA	-	1	
1	ALUMINIUM PLATE	50x325x3t mm.	ALUMINIUM	1	
NO.	DESDRIPTION	DIMENSION	MATERIAL	QTY	REMARK



D. P. TRADING CO.,LTD.

1473/3 Pattanakarn 31/1, Pattanakarn Road, Suan Luang, Bangkok 10250
TEL. (02) 319 4483 FAX. (02) 318 1602-3

Draw by SEKSAK	Name : แผง CB 1P 10A 6KA ,TB 4P 25A แบบ ALUMINIUM	Dwg No. DWP-AMC-009/00
Design by		Scale 1 : 2
Approved by	Project : (กรมทางหลวง)	Paper Size A4
Date 05/10/2561		Sheet No. 01
		Sheet Total 01

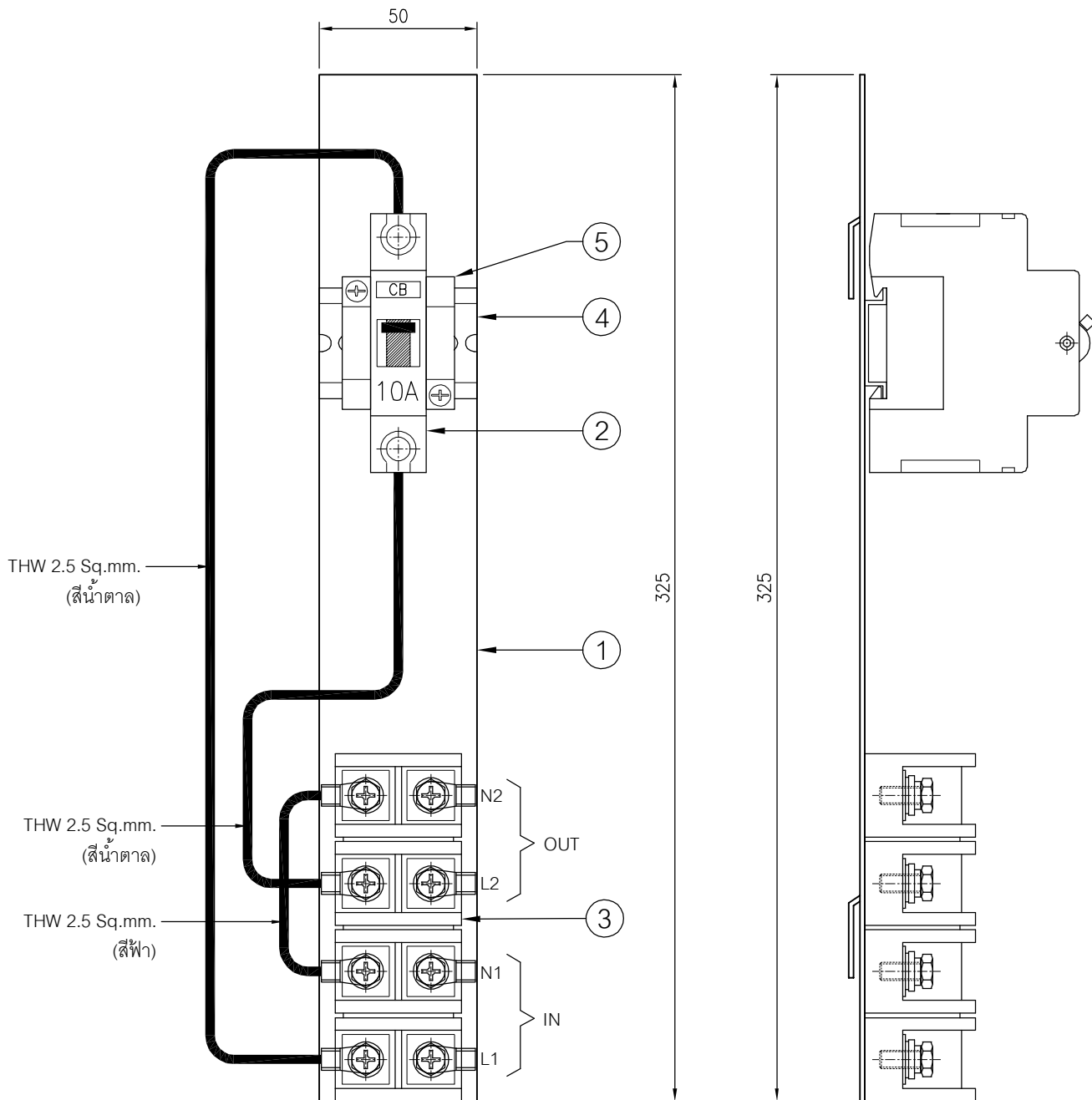

FRONT VIEW
SCALE 1 : 2

SIDE VIEW
SCALE 1 : 2

NOTE :

- ALL DIMENSION ARE IN MILLIMETERS

5	STOPPER	-	-	2	
4	รางปิดกั้น	-	ALUMINIUM	1	
3	TERMINAL BLOCK	4P 60A	-	1	
2	CIRCUIT BREAKER	1P 10A IC 6KA	-	1	
1	ALUMINIUM PLATE	50x325x3t mm.	ALUMINIUM	1	
NO.	DESDRIPTION	DIMENSION	MATERIAL	QTY	REMARK



D. P. TRADING CO.,LTD.

1473/3 Pattanakarn 31/1, Pattanakarn Road, Suan Luang, Bangkok 10250
TEL. (02) 319 4483 FAX. (02) 318 1602-3

Draw by SEKSAK	Name : แผง CB 1P 10A 6KA ,TB 4P 60A แบบ ALUMINIUM	Dwg No. DWP-AMC-010/00
Design by		Scale 1 : 2
Approved by	Project : (กรมทางหลวง)	Paper Size A4
Date 05/10/2561		Sheet No. 01
		Sheet Total 01

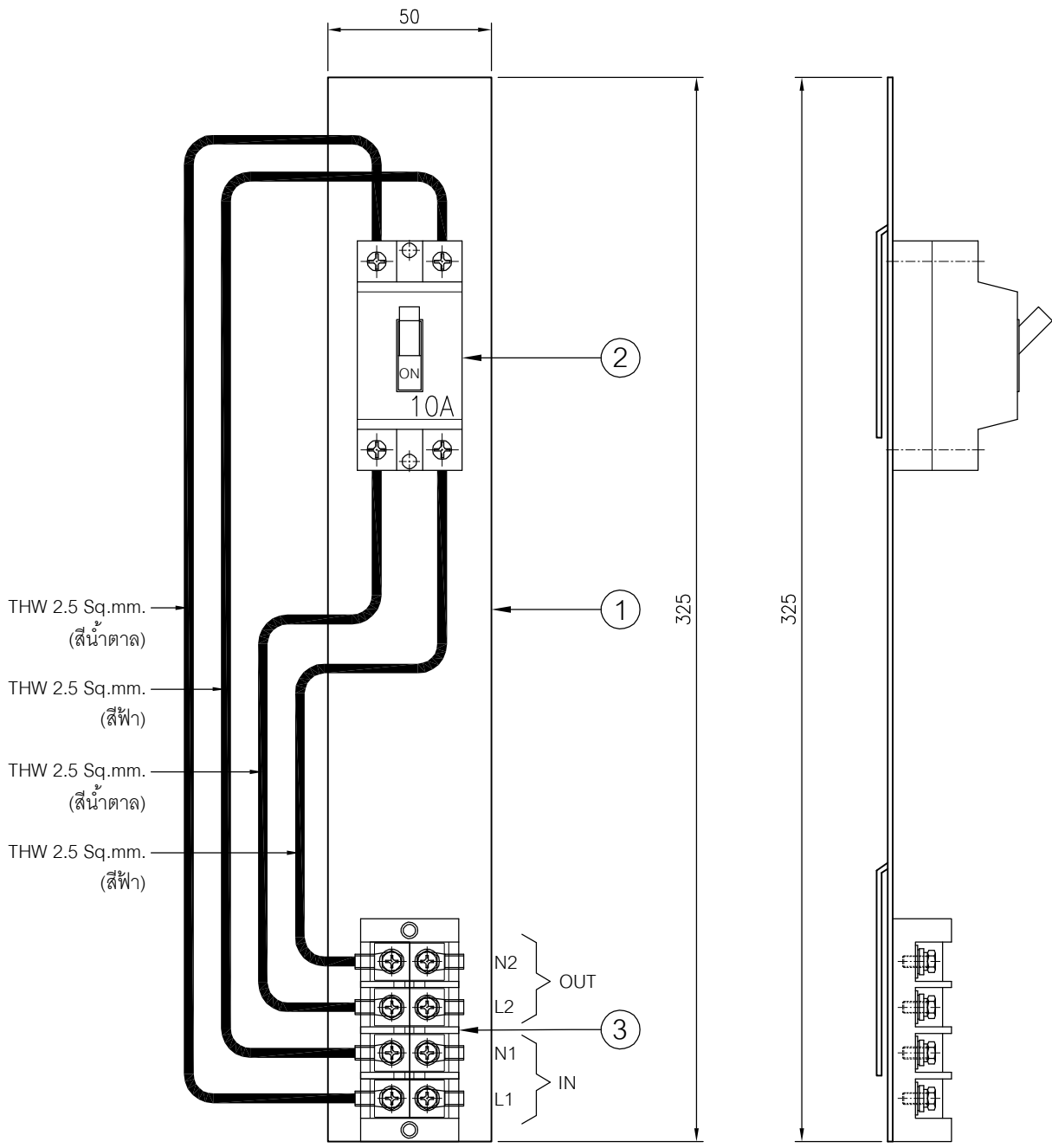

FRONT VIEW
SCALE 1 : 2

SIDE VIEW
SCALE 1 : 2

NOTE :
- ALL DIMENSION ARE IN MILLIMETERS

NO.	DESDRIPTION	DIMENSION	MATERIAL	QTY	REMARK
3	TERMINAL BLOCK	4P 25A	-	1	
2	SAFETY BREAKER	2P 10A	-	1	
1	ALUMINIUM PLATE	50x325x3t mm.	ALUMINIUM	1	



D. P. TRADING CO.,LTD.

1473/3 Pattanakarn 31/1, Pattanakarn Road, Suan Luang, Bangkok 10250
TEL. (02) 319 4483 FAX. (02) 318 1602-3

Draw by SEKSAK	Name : แผง SAFETY BREAKER 2P 10A TB 4P 25A แบบ ALUMINIUM	Dwg No. DWP-AMC-015/00
Design by	Project : กิ่งเดี่ยว / กิ่งคู่ (กรรมทางหลวงชนบท)	Scale 1 : 2
Approved by		Paper Size A4
Date 05/10/2561		Sheet No. 01
		Sheet Total 01

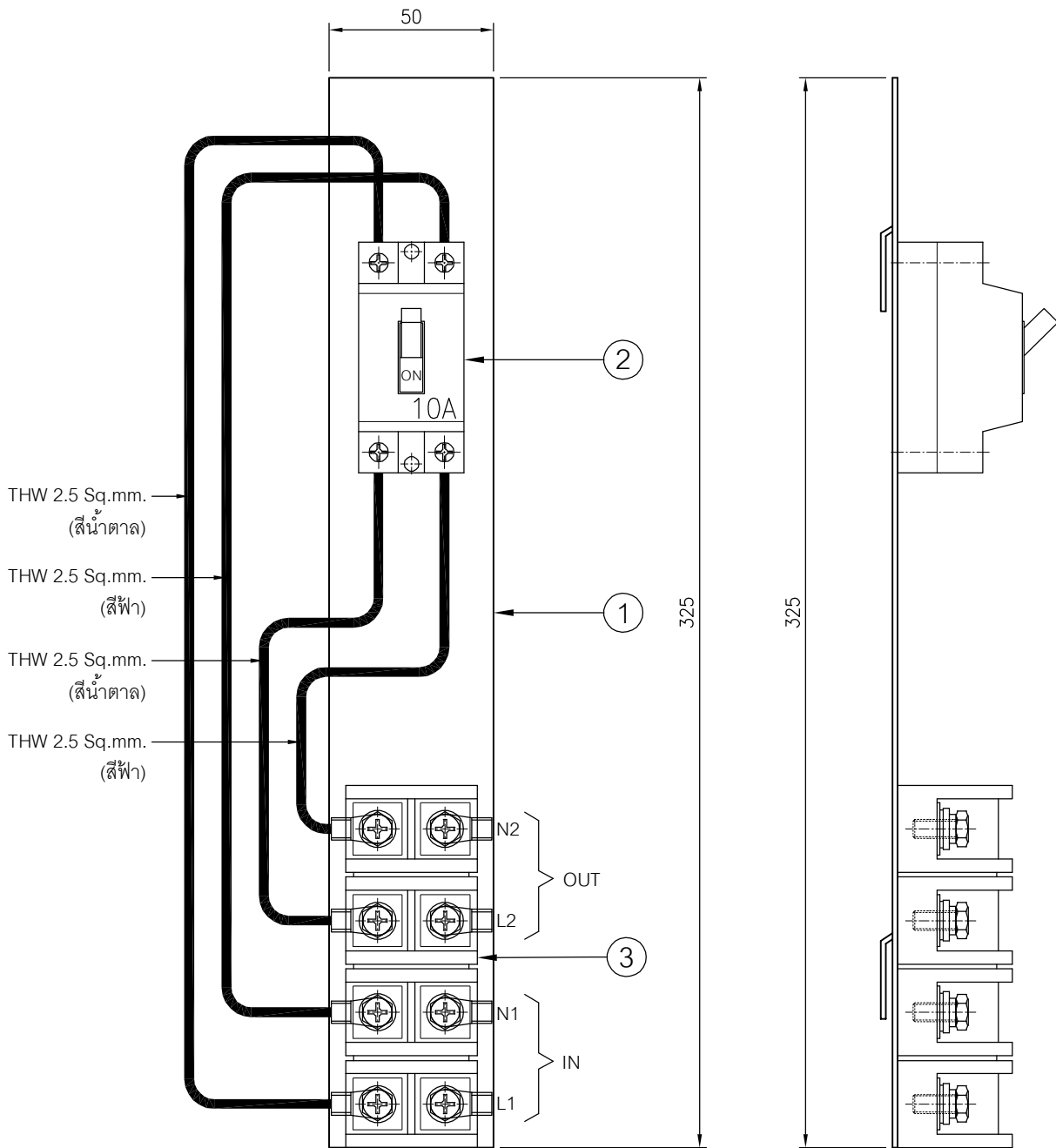

FRONT VIEW
SCALE 1 : 2

SIDE VIEW
SCALE 1 : 2

NOTE :

- ALL DIMENSION ARE IN MILLIMETERS

3	TERMINAL BLOCK	4P 60A	-	1	
2	SAFETY BREAKER	2P 10A	-	1	
1	ALUMINIUM PLATE	50x325x3t mm.	ALUMINIUM	1	
NO.	DESDRIPTION	DIMENSION	MATERIAL	QTY	REMARK



D. P. TRADING CO.,LTD.

1473/3 Pattanakarn 31/1, Pattanakarn Road, Suan Luang, Bangkok 10250
TEL. (02) 319 4483 FAX. (02) 318 1602-3

Draw by SEKSAK	Name : แผง SAFETY BREAKER 2P 10A TB 4P 60A แบบ ALUMINIUM	Dwg No. DWP-AMC-016/00
Design by	Project : กิ่งเดี่ยว / กิ่งคู่ (กรรมทางหลวงชนบท)	Scale 1 : 2
Approved by		Paper Size A4
Date 05/10/2561		Sheet No. 01
		Sheet Total 01

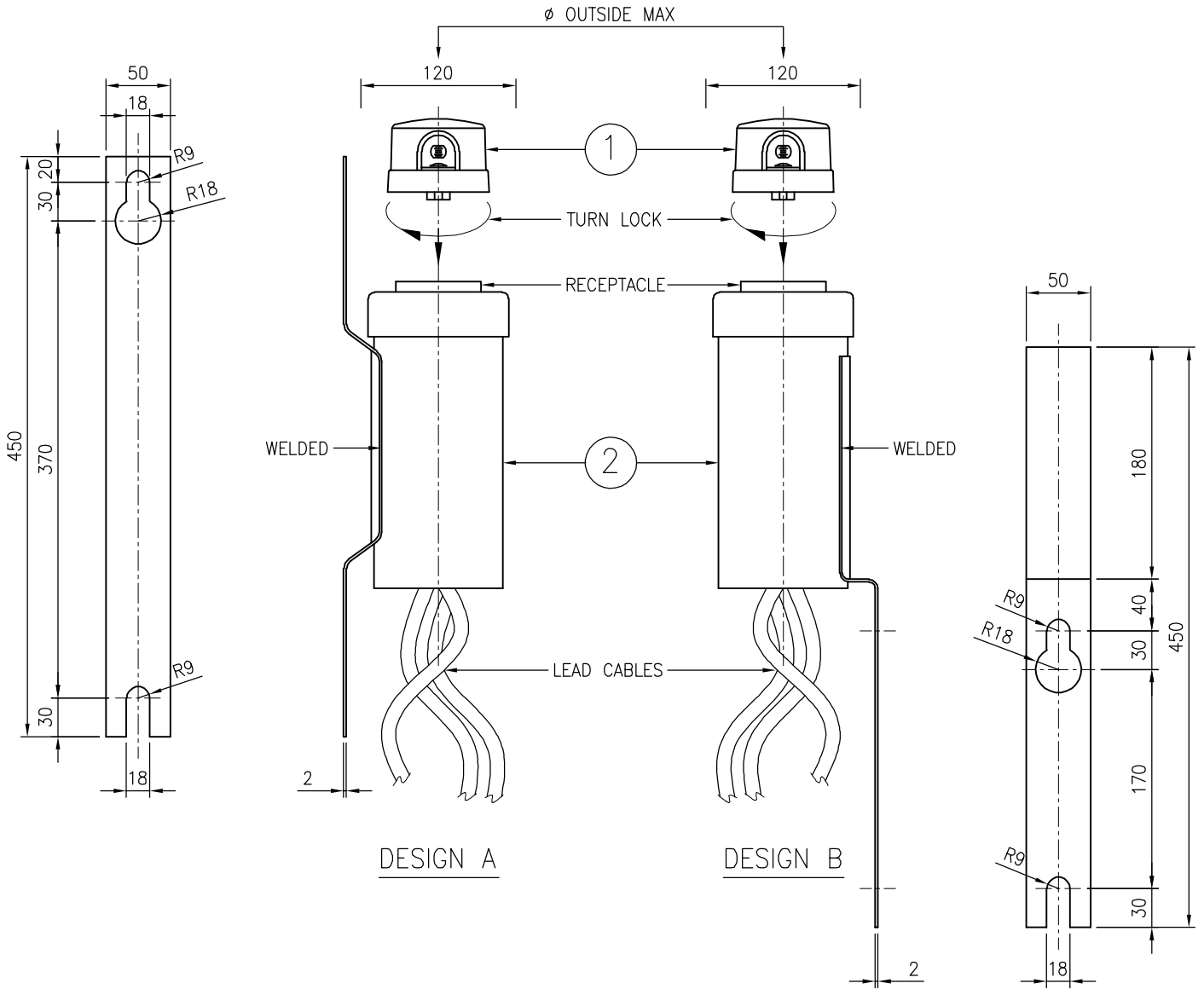

DESIGN A

DESIGN B

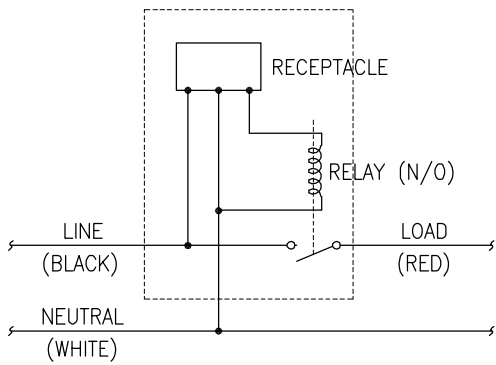

WIRING DIAGRAM

ITEM	DESCRIPTION
1	PHOTO ELECTRIC CONTROL
2	CONTROL RELAY, WEATHERPROOF STAINLESS STEEL CASE, COMPLETE WITH CONTACTOR RECEPTACLE, LEAD CABLES AND BRACKET.

NOTE :

- ALL DIMENSION ARE IN MILLIMETERS



D. P. TRADING CO.,LTD.

1473/3 Pattanakarn 31/1, Pattanakarn Road, Suan Luang, Bangkok 10250

TEL. (02) 319 4483

FAX. (02) 318 1602-3

Draw by SEKSAK	Name :	Dwg No. DWP-AMC-036/00
Design by	PROJECT : PHOTO SWITCH TYPE - A	Scale 1 : 5
Approved by		Paper Size A4
Date 14/12/2561	Project :	Sheet No. 01
		Sheet Total 01

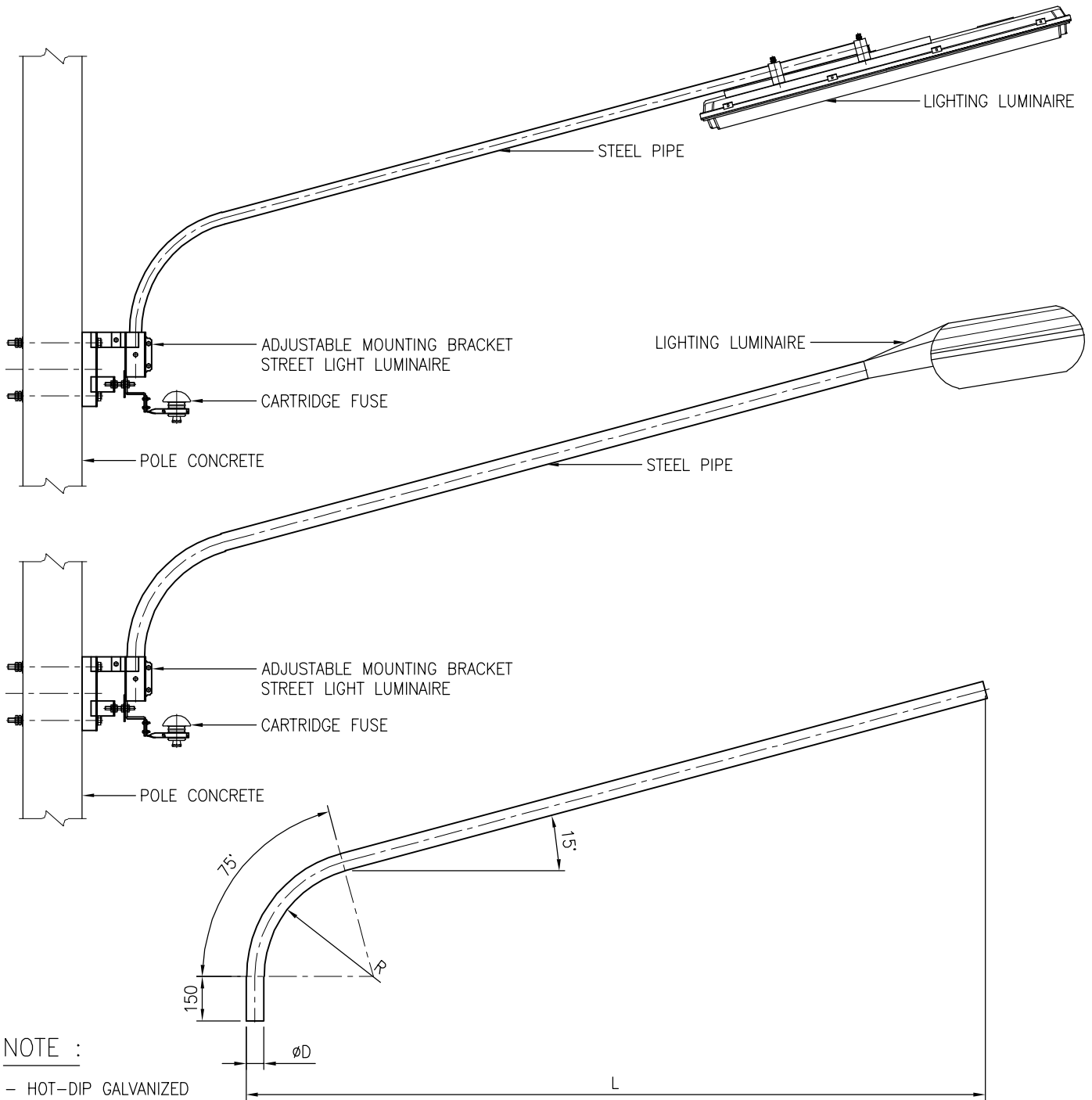

NOTE :

- HOT-DIP GALVANIZED

PIPE (Ø D)	LONG (L = mm.)	RADIAL (R = mm.)	REMARK
Ø 1 1/4"	1,100 mm.	280 mm.	-
Ø 1 1/2"	1,200 mm.	280 mm.	-
Ø 2"	1,500 mm.	280 mm.	-
	1,800 mm.	400 mm.	-
	2,000 mm.	400 mm.	-
	2,500 mm.	400 mm.	-
	2,800 mm.	400 mm.	-



D. P. TRADING CO.,LTD.

1473/3 Pattanakarn 31/1, Pattanakarn Road, Suan Luang, Bangkok 10250
 TEL. (02) 319 4483 FAX. (02) 318 1602-3

Draw by	SEKSAK	Name :	STREET LIGHTING ROD TYPE-1		Dwg No.	DWP-ABK-001/00	
Design by		Project :			Scale	NTS	Paper Size A4
Approved by		Date	12/09/2561		Sheet No.		01
					Sheet Total		01



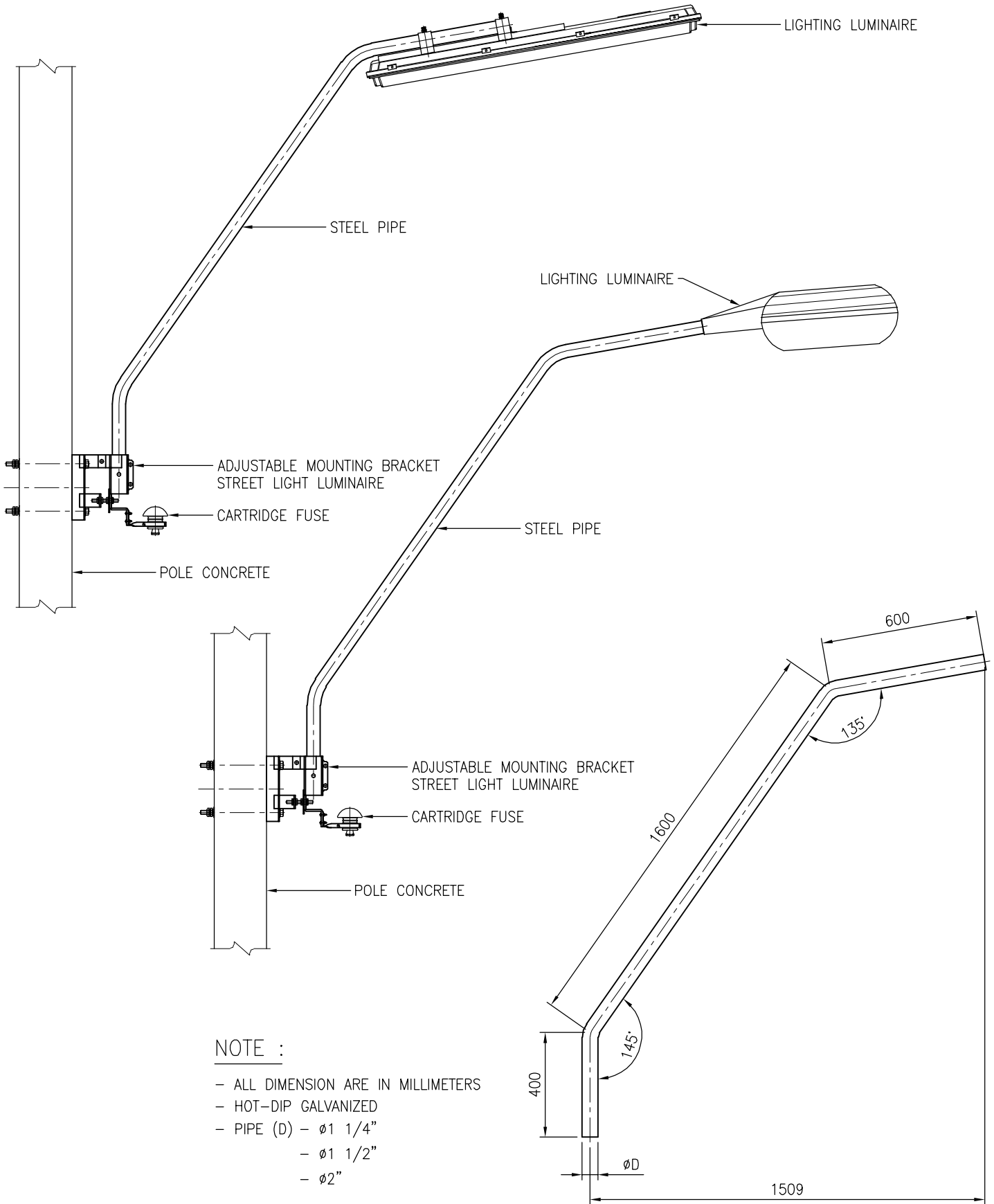

NOTE :

- ALL DIMENSION ARE IN MILLIMETERS
- HOT-DIP GALVANIZED
- PIPE (D) - $\phi 1 \frac{1}{4}$ "
- $\phi 1 \frac{1}{2}$ "
- $\phi 2$ "



D. P. TRADING CO.,LTD.

1473/3 Pattanakarn 31/1, Pattanakarn Road, Suan Luang, Bangkok 10250
 TEL. (02) 319 4483 FAX. (02) 318 1602-3

Draw by SEKSAK	Name : STREET LIGHTING ROD TYPE-2	Dwg No. DWP-ABK-002/00
Design by	Project :	Scale NTS Paper Size A4
Approved by		Sheet No. 01
Date 12/09/2561		Sheet Total 01

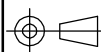

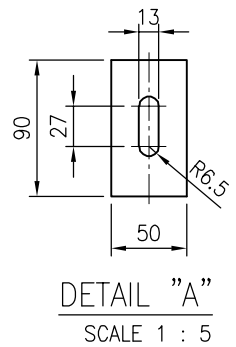
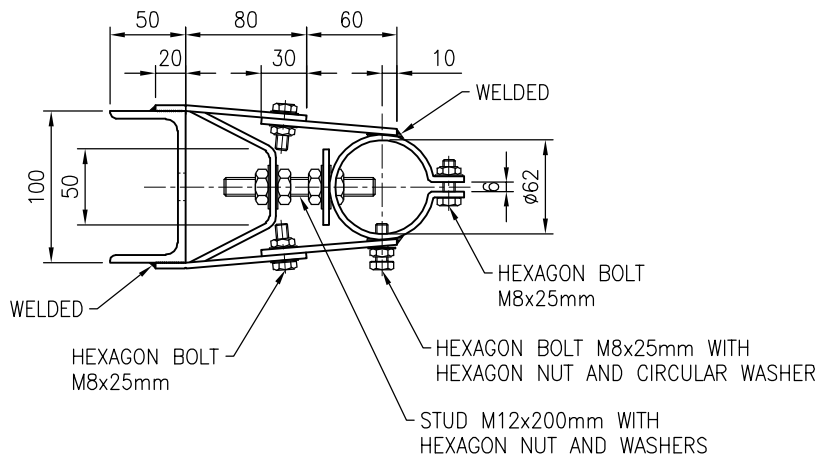
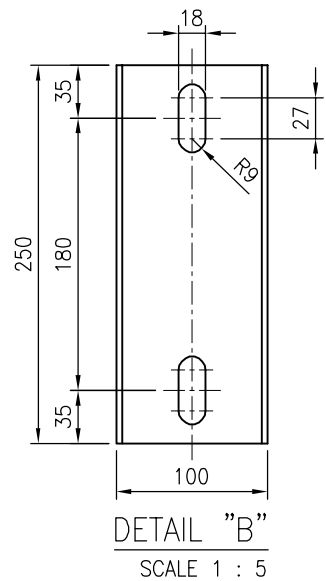
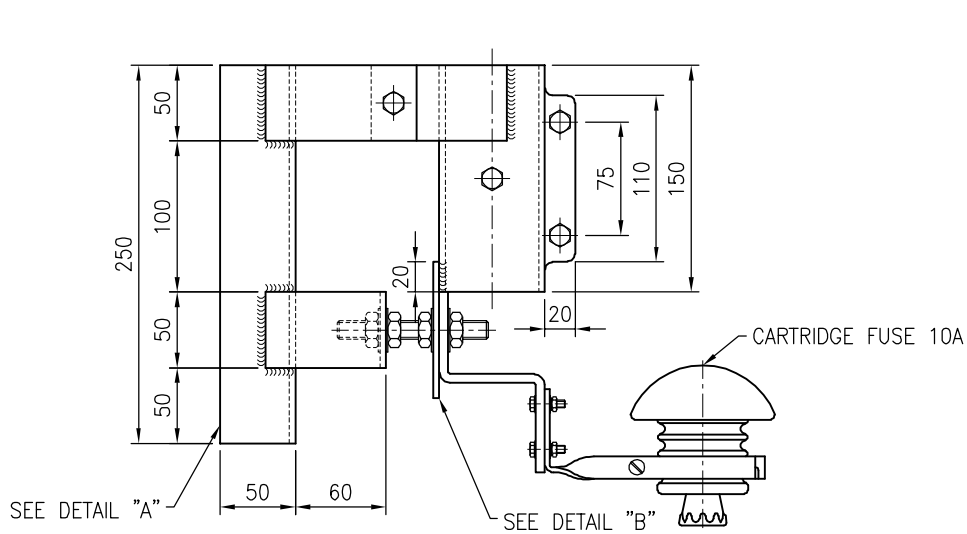

NOTE :

- IRON SHEET THICKNESS 4 MM. BOTH SIDES ARE PAINTED FOR RUST PROTECTION OR GAVANIZED IF REQUIRED.
- 2-12 MM. BOLT FOR ONE SET WITH WASHER BOLT LENGTH ACCORDING TO DIAMETER OF ELECTRIC POLE
- ALL DIMENTIONS ARE IN MILLIMETERS



D. P. TRADING CO.,LTD.

1473/3 Pattanakarn 31/1, Pattanakarn Road, Suan Luang, Bangkok 10250
TEL. (02) 319 4483 FAX. (02) 318 1602-3

Draw by	SEKSAK	Name :	ADJUSTABLE MOUNTING BRACKET Ø2" FOR STREET LIGHT LUMINAIRE		Dwg No.	DWP-AMB-002/00	
Design by		Scale	1 : 5	Paper Size	A4		
Approved by		Project :					
Date	12/09/2561				Sheet No.	01	
					Sheet Total	01	

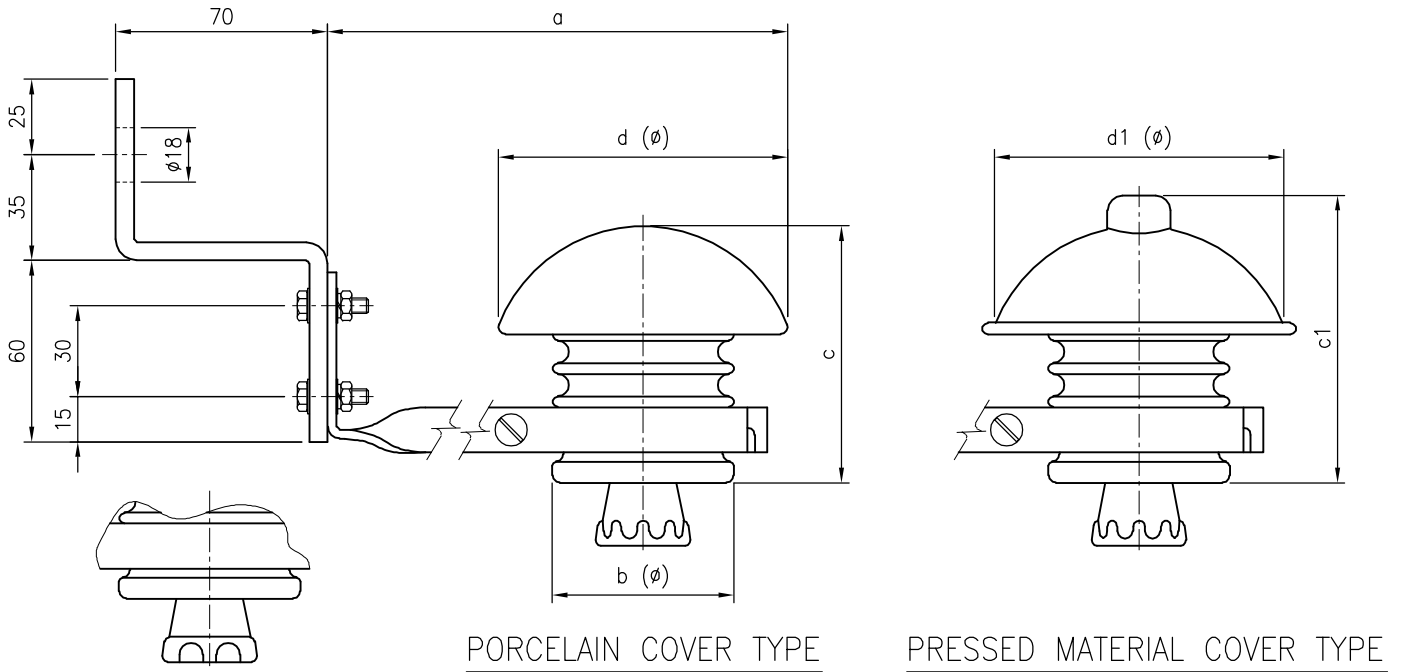

ALTERNATIVE FUSE CAP

PORCELAIN COVER TYPE

CDC. CAT. NO.	DIMENSION (MM.)				MAX.CURRENT (A)	MAX.CURRENT (V)	THREAD	MAX.COND. SIZE (mm2)
	a	b(ø)	c	d(ø)				
AF. - 25A.	160	60	85	105	25	500	E-27	6.0
AF. - 63A.	165	70	95	105	63	500	E-33	16.0

PRESSED MATERIAL COVER TYPE

CDC. CAT. NO.	DIMENSION (MM.)				MAX.CURRENT (A)	MAX.CURRENT (V)	THREAD	MAX.COND. SIZE (mm2)
	a	b(ø)	c1	d1(ø)				
AF. - 25A.	160	60	95	105	25	500	E-27	6.0
AF. - 63A.	165	70	100	105	63	500	E-33	16.0

MATERIALS :

- INSULATING BODY : PORCELAIN
- COVER : PORCELAIN OR PRESSED MATERIAL
- CONTACT : COPPER NICKELLED
- FLAT STEEL : SIZE 30 x 5 MM. GALVANIZED

REMARK :

- ALL DIMENSION ARE IN MILLIMETERS
- TOLERANCE ± 1.5%

	D. P. TRADING CO.,LTD.			
	1473/3 Pattanakarn 31/1, Pattanakarn Road, Suan Luang, Bangkok 10250			
	TEL. (02) 319 4483		FAX. (02) 318 1602-3	
	Draw by	SEKSAK	Name :	
Design by		RAINTIGHT AERIAL FUSE FOR D-CARTRIDGE FUSE		
Approved by		Project :		
Date	14/12/2561			
		Dwg No.	DWP-AMC-034/00	
		Scale	NTS	
		Paper Size	A4	
		Sheet No.	01	
		Sheet Total	01	

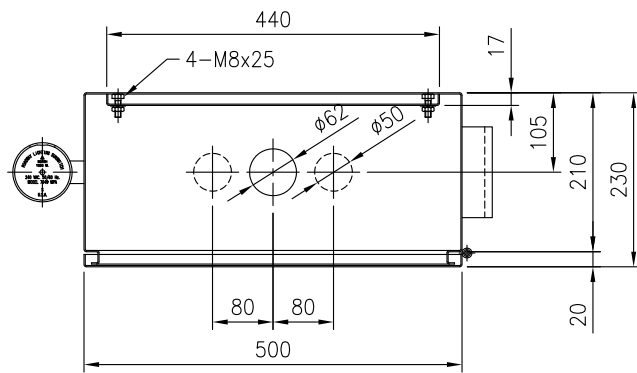
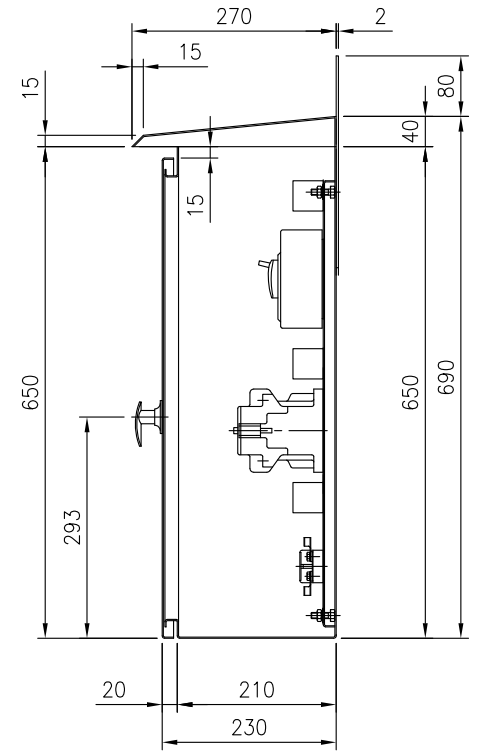
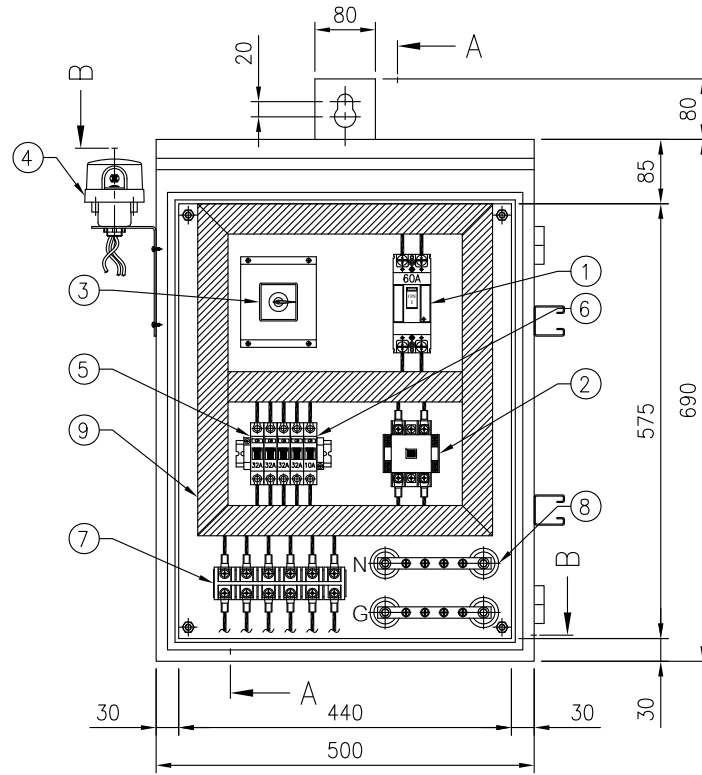
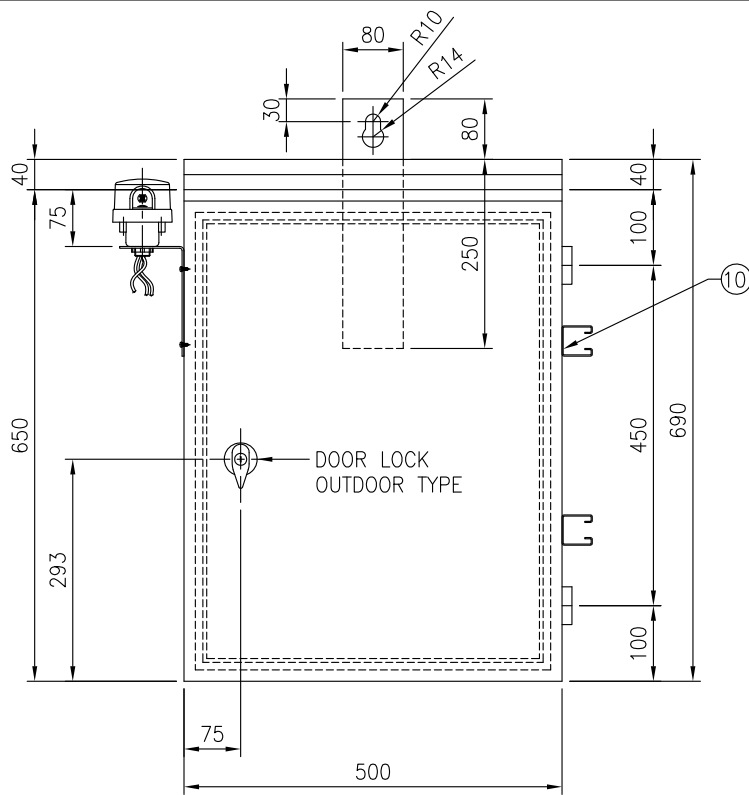

NOTE :

- ALL DIMENSION ARE IN MILLIMETERS
- MATERIAL STEEL SHEET T=2.0mm.
- CUBICLE TYPE : OUT DOOR
- PROTECTION DEGREE : IP 54
- COLOR : RAL 7032
- WEIGHT : kg

ITEM	DESCRIPTION	TYPE	MODEL	QTY
1	MCCB 2P, 60A, 240V			1 SET
2	MAGNETIC CONTACTOR 3P-65A			1 SET
3	SELECTOR SWITCH 3 STEP			1 SET
4	PHOTO SWITCH			1 SET
5	CB 32A, 1P			4 SETS
6	CB 10A, 1P			1 SET
7	TERMINAL 60A, 1P			6 SETS
8	BUS BAR + ลูกถ้วย BUS BAR			2 SETS
9	PVC WIRE DUCT 40x40x2,000mm.			1 SET
10	C-CHANNEL			2 SETS

D. P. TRADING CO.,LTD.

1473/3 Pattannakarn 31/1, Pattannakarn Road, Suan Luang, Bangkok 10250

TEL. (02) 319 4483 FAX. (02) 318 1602-3

Draw by : D.SURACHAI	Name : ตู้ควบคุม ชนิดขวน แบบไม่มี TIMER 2P , 60A , 240V	Dwg No. :
Design by :	กรมทางหลวง	Scale : 1 : 10 Paper Size : A4
Approved by :		Sheet No. : 01
Date : 08/06/2566	Project :	Sheet Total : 01

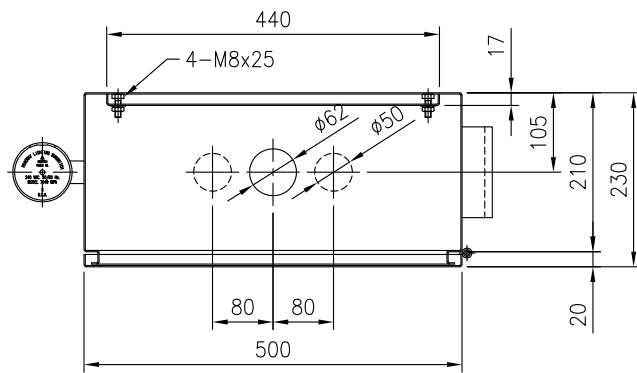
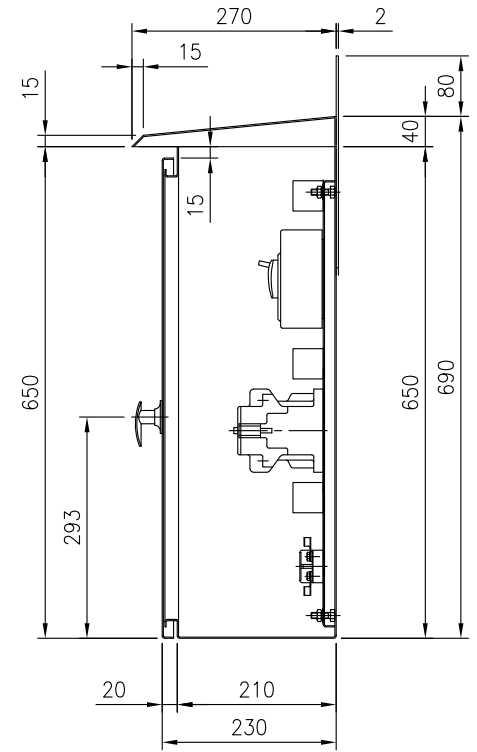
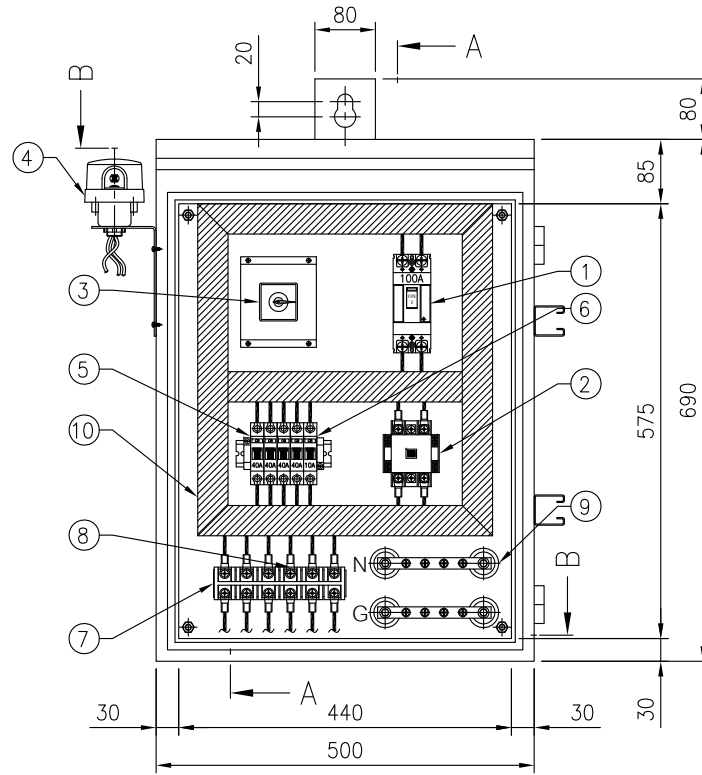
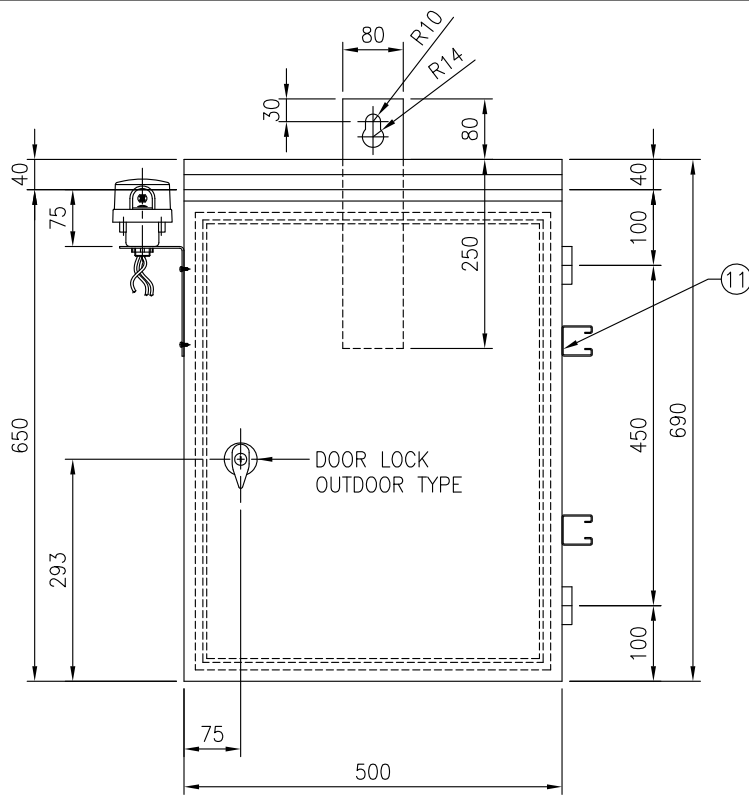

NOTE :

- ALL DIMENSION ARE IN MILLIMETERS
- MATERIAL STEEL SHEET T=2.0mm.
- CUBICLE TYPE : OUT DOOR
- PROTECTION DEGREE : IP 54
- COLOR : RAL 7032
- WEIGHT : kg

ITEM	DESCRIPTION	TYPE	MODEL	QTY
1	MCCB 2P, 100A, 240V			1 SET
2	MAGNETIC CONTACTOR 3P-65A			1 SET
3	SELECTOR SWITCH 3 STEP			1 SET
4	PHOTO SWITCH			1 SET
5	CB 40A, 1P			4 SETS
6	CB 10A, 1P			1 SET
7	TERMINAL 100A, 1P			2 SETS
8	TERMINAL 60A, 1P			4 SETS
9	BUS BAR + ลูกถ้วย BUS BAR			2 SETS
10	PVC WIRE DUCT 40x40x2,000mm.			1 SET
11	C-CHANNEL			2 SETS

D. P. TRADING CO.,LTD.

1473/3 Pattannakarn 31/1, Pattannakarn Road, Suan Luang, Bangkok 10250

TEL. (02) 319 4483 FAX. (02) 318 1602-3

Draw by : D.SURACHAI	Name : ตู้ควบคุม ชนิดแชน แบบไม่มี TIMER 2P , 100A , 240V	Dwg No. :	
Design by :	กรมทางหลวง	Scale : 1 : 10	Paper Size : A4
Approved by :		Sheet No. : 01	Sheet Total : 01
Date : 08/06/2566			

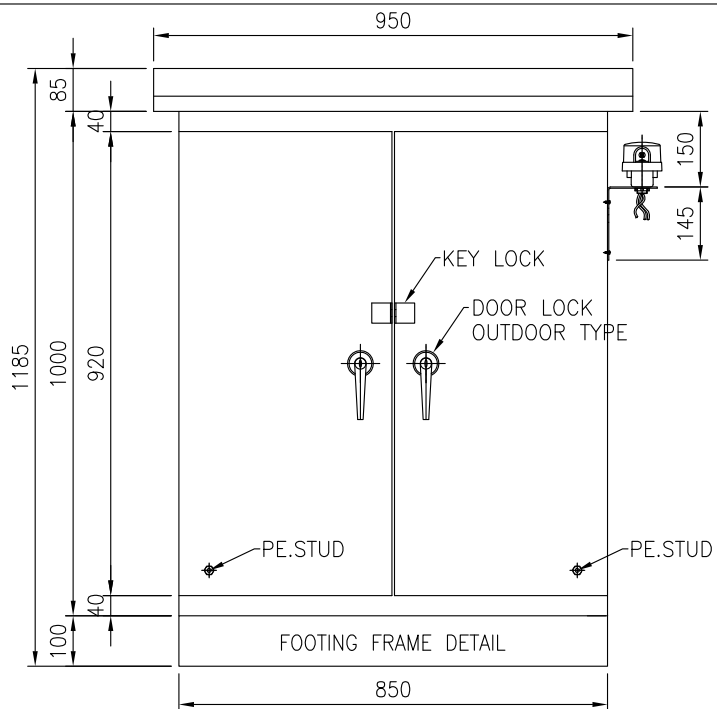

FRONT VIEW
SCALE 1 : 15

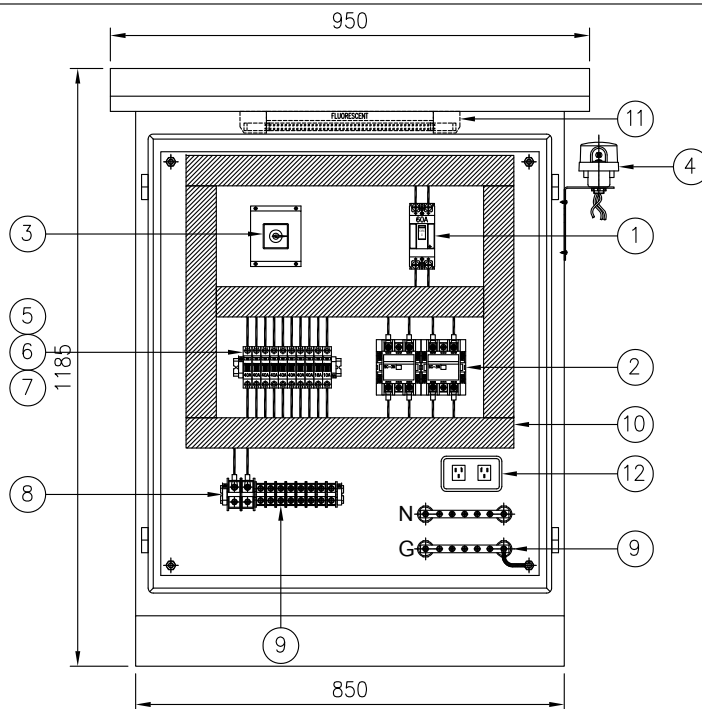

FRONT VIEW
SCALE 1 : 15

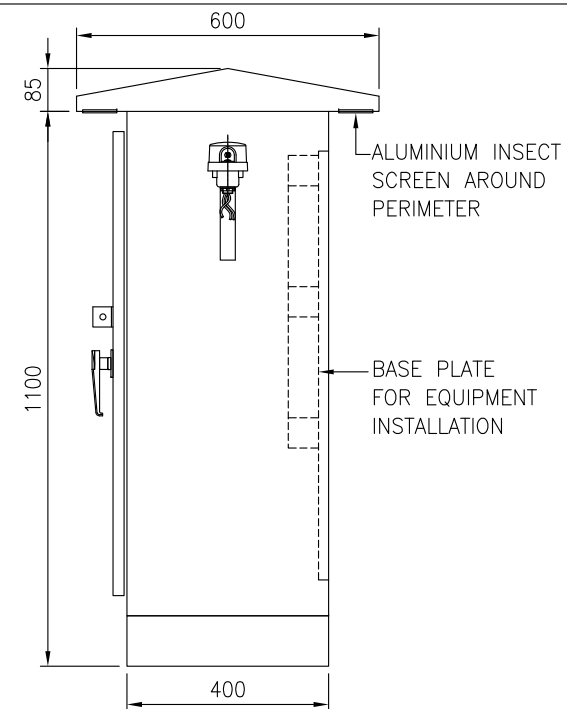

SIDE VIEW
SCALE 1 : 15

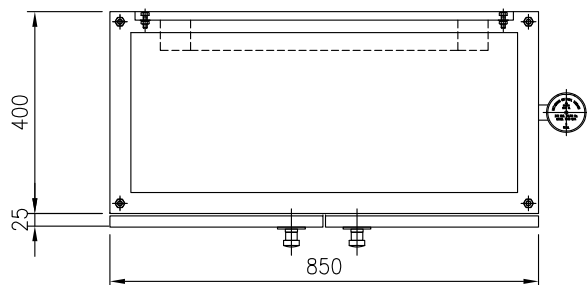

TOP VIEW
SCALE 1 : 15

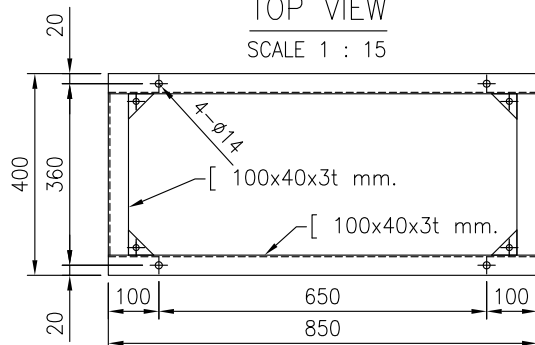

FOOTING FRAME DETAIL
SCALE 1 : 15

NOTE :

- ALL DIMENSION ARE IN MILLIMETERS
- MATERIAL STEEL SHEET T=2.0mm.
- CUBICLE TYPE : OUT DOOR
- PROTECTION DEGREE : IP 54
- COLOR : RAL 7032
- WEIGHT : kg

ITEM	DESCRIPTION	TYPE	MODEL	QTY
1	MCCB 2P, 60A, 240V			1 SET
2	MAGNETIC CONTACTOR 3P-65A			2 SETS
3	SELECTOR SWITCH 3 STEP			1 SET
4	PHOTO SWITCH			1 SET
5	CB 32A, 1P			8 SETS
6	CB 16A, 1P			1 SET
7	CB 10A, 1P			1 SET
8	TERMINAL 60A, 1P			10 SETS
9	BUS BAR + ลูกถ้วย BUS BAR			2 SETS
10	PVC WIRE DUCT 40x40x2,000mm.			1 SET
11	FLUORESCENT LAMP LED 9W			1 SET
12	DUPLEX RECEPTAGLE 2P+N			1 SET

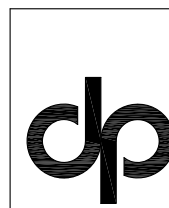

D. P. TRADING CO.,LTD.

1473/3 Pattannakarn 31/1, Pattannakarn Road, Suan Luang, Bangkok 10250
TEL. (02) 319 4483 FAX. (02) 318 1602-3

Draw by : D.SURACHAI	Name : ตุ๋นคุณ ชนิตตั้งพันธ์ แบบไม่มี TIMER 2P , 60A , 240V	Dwg No. :
Design by :	Project : กรมทางหลวง	Scale : 1 : 10 Paper Size : A4
Approved by :	Date : 08/06/2566	Sheet No. : 01 Sheet Total : 01

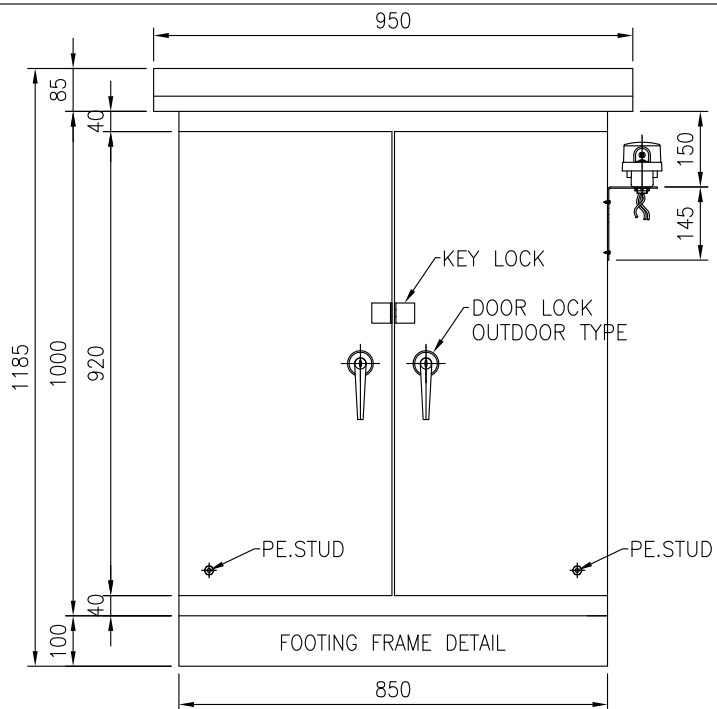

FRONT VIEW
SCALE 1 : 15

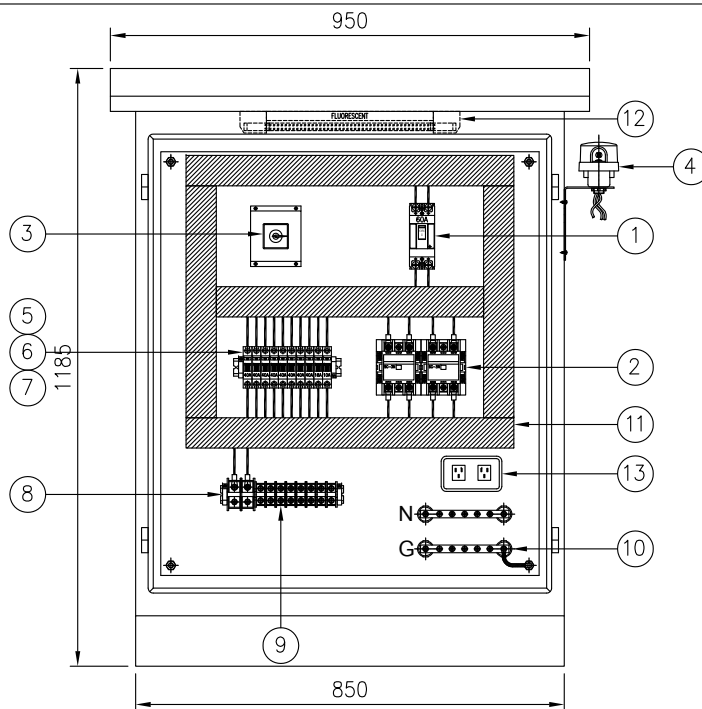

FRONT VIEW
SCALE 1 : 15

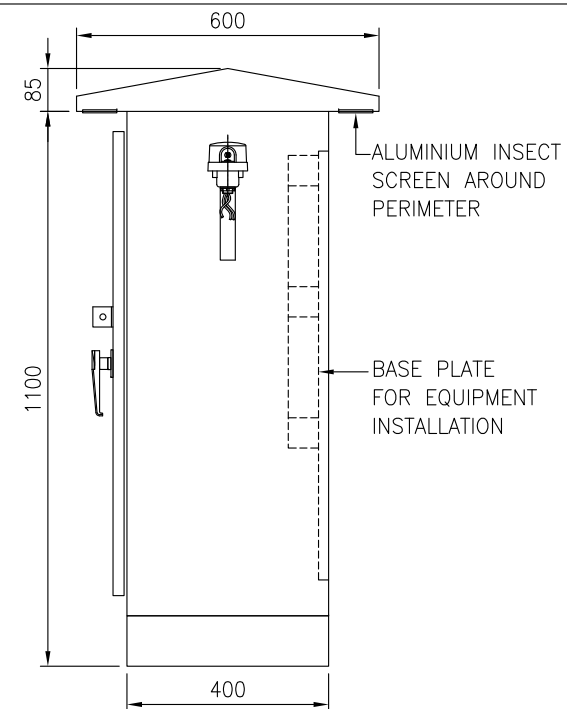

SIDE VIEW
SCALE 1 : 15

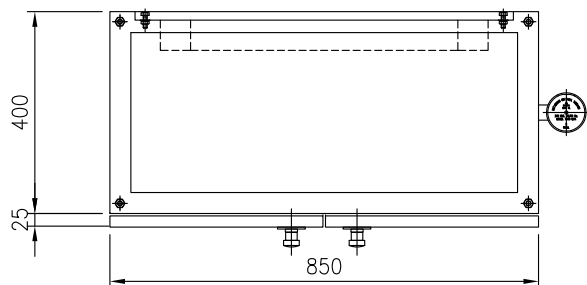

TOP VIEW
SCALE 1 : 15

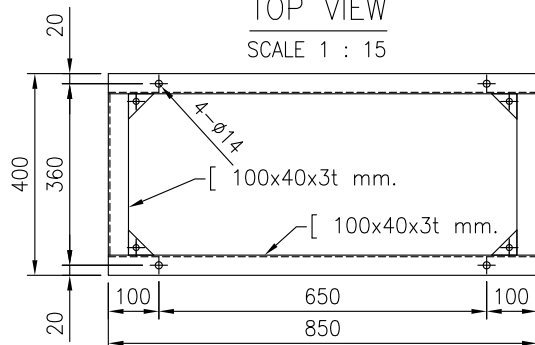

FOOTING FRAME DETAIL
SCALE 1 : 15

NOTE :

- ALL DIMENSION ARE IN MILLIMETERS
- MATERIAL STEEL SHEET T=2.0mm.
- CUBICLE TYPE : OUT DOOR
- PROTECTION DEGREE : IP 54
- COLOR : RAL 7032
- WEIGHT : kg

ITEM	DESCRIPTION	TYPE	MODEL	QTY
1	MCCB 2P, 100A, 240V			1 SET
2	MAGNETIC CONTACTOR 3P-65A			2 SETS
3	SELECTOR SWITCH 3 STEP			1 SET
4	PHOTO SWITCH			1 SET
5	CB 40A, 1P			8 SETS
6	CB 16A, 1P			1 SET
7	CB 10A, 1P			1 SET
8	TERMINAL 100A, 1P			2 SETS
9	TERMINAL 60A, 1P			8 SETS
10	BUS BAR + ลูกถ้วย BUS BAR			2 SETS
11	PVC WIRE DUCT 40x40x2,000mm.			1 SET
12	FLUORESCENT LAMP LED 9W			1 SET
13	DUPLEX RECEPTAGLE 2P+N			1 SET

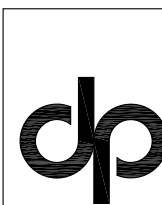

D. P. TRADING CO.,LTD.

1473/3 Pattannakarn 31/1, Pattannakarn Road, Suan Luang, Bangkok 10250
TEL. (02) 319 4483 FAX. (02) 318 1602-3

Draw by : D.SURACHAI	Name : ตุ๋นคุณ ชนิตตั้งพันธ์ แบบไม่มี TIMER 2P , 100A , 240V	Dwg No. :
Design by :	Project : กรมทางหลวง	Scale : 1 : 10 Paper Size : A4
Approved by :	Date : 08/06/2566	Sheet No. : 01 Sheet Total : 01

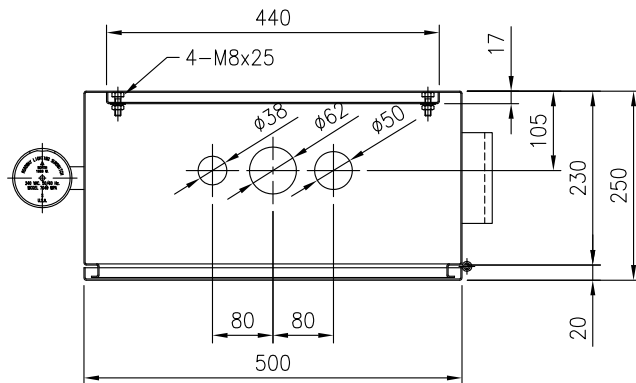
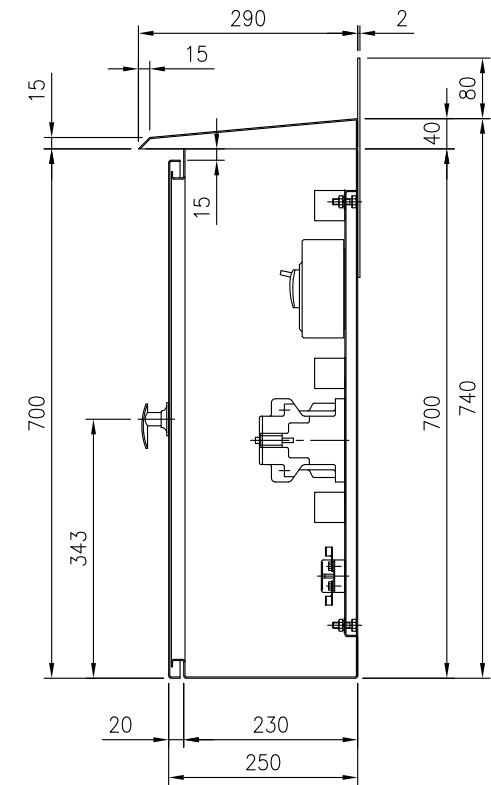
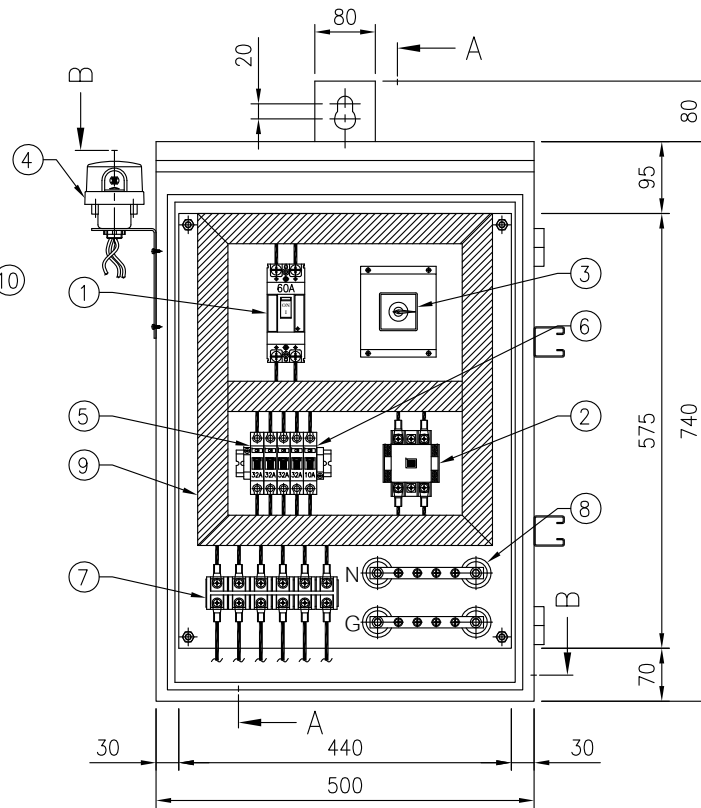
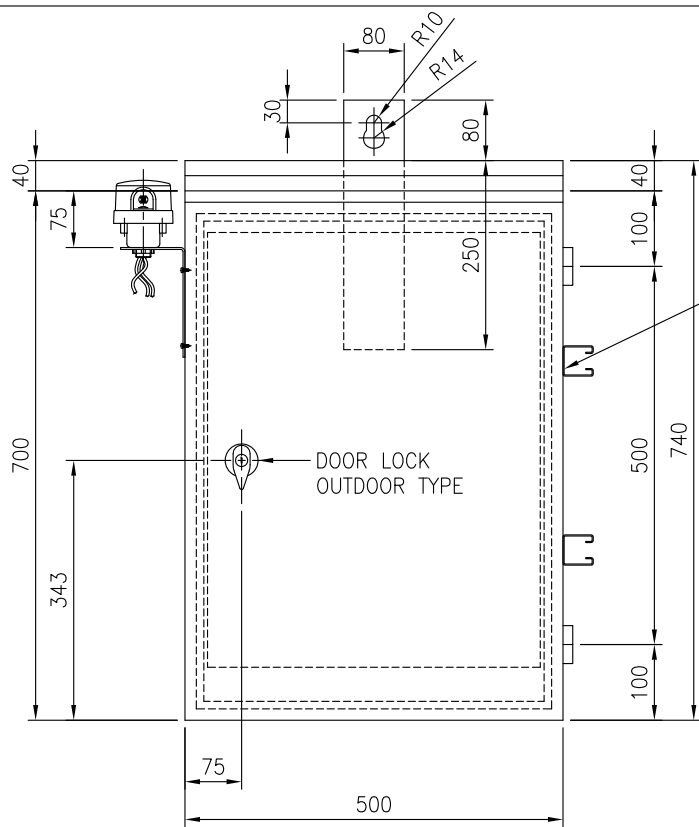

NOTE :

- ALL DIMENSION ARE IN MILLIMETERS
- MATERIAL STAINLESS T=2.0mm.

ITEM	DESCRIPTION	TYPE	MODEL	QTY
1	MCCB 2P, 60A, 240V			1 SET
2	MAGNETIC CONTACTOR 3P-65A			1 SET
3	SELECTOR SWITCH 3 STEP			1 SET
4	PHOTO SWITCH			1 SET
5	CB 32A, 1P			4 SETS
6	CB 10A, 1P			1 SET
7	TERMINAL 60A, 1P			6 SETS
8	BUS BAR + ลูกถ้วย BUS BAR			2 SETS
9	PVC WIRE DUCT 40x40x2,000mm.			1 SET
10	C-CHANNEL			2 SETS

D. P. TRADING CO.,LTD.

1473/3 Pattannakarn 31/1, Pattannakarn Road, Suan Luang, Bangkok 10250

TEL. (02) 319 4483 FAX. (02) 318 1602-3

Draw by : D.SURACHAI	Name : ตู้ควบคุม STL ชนิดขนวน แบบไม่มี TIMER 2P , 60A , 240V	Dwg No. :
Design by :	กรมทางหลวงชนบท	Scale : 1 : 10
Approved by :		Sheet No. : 01
Date : 08/06/2566		Sheet Total : 01

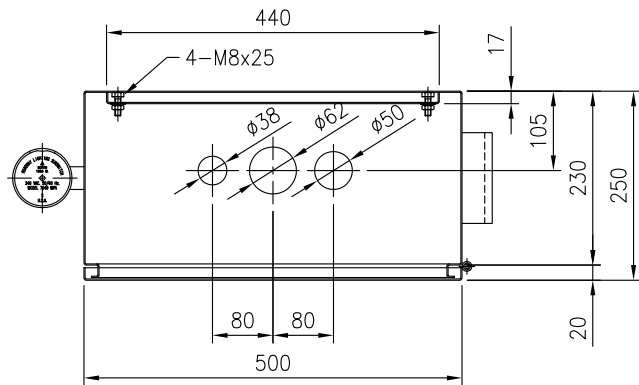
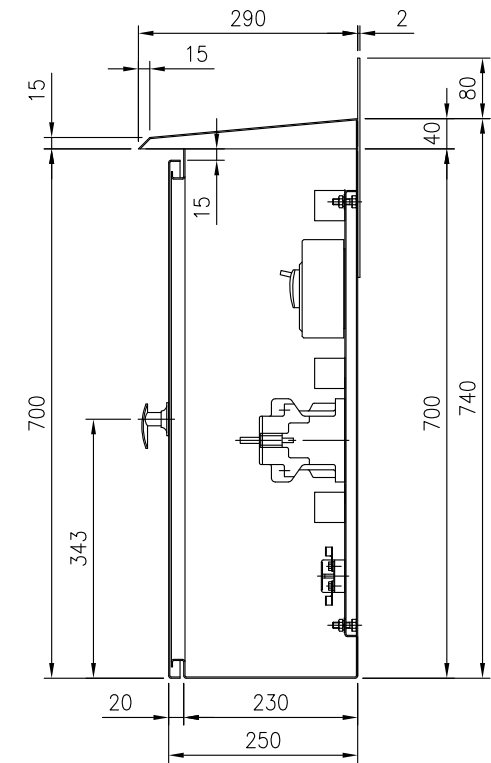
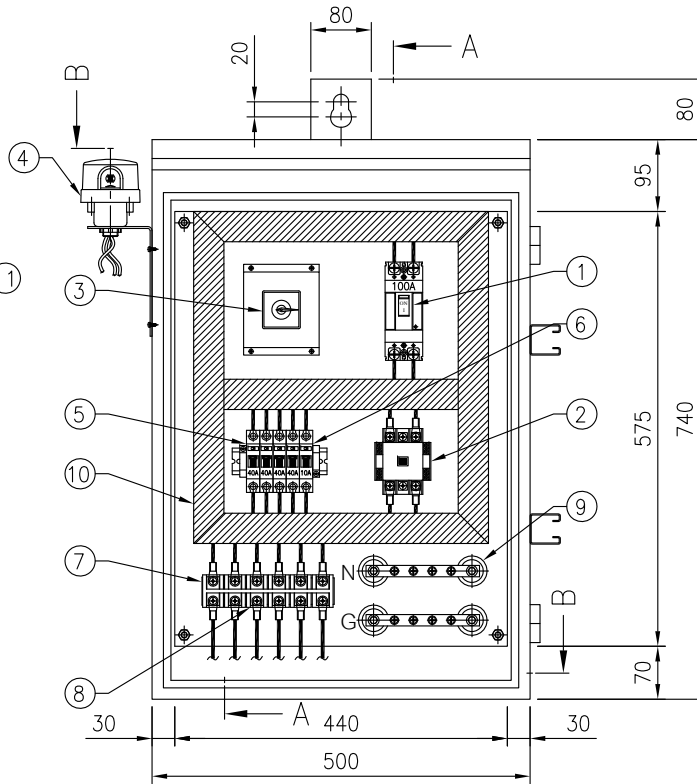
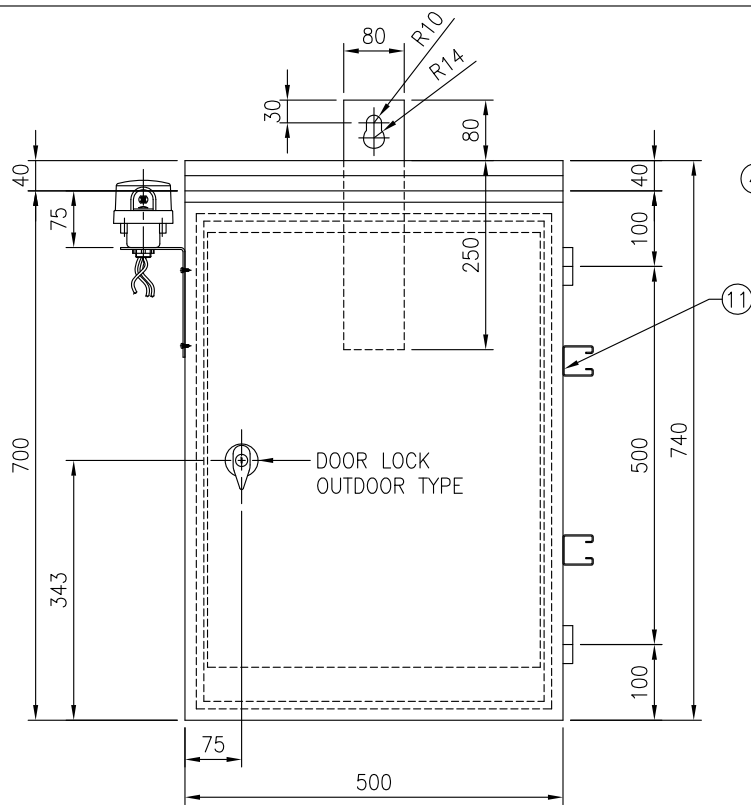

NOTE :

- ALL DIMENSION ARE IN MILLIMETERS
- MATERIAL STAINLESS T=2.0mm.

ITEM	DESCRIPTION	TYPE	MODEL	QTY
1	MCCB 2P, 100A, 240V			1 SET
2	MAGNETIC CONTACTOR 3P-65A			1 SET
3	SELECTOR SWITCH 3 STEP			1 SET
4	PHOTO SWITCH			1 SET
5	CB 40A, 1P			4 SETS
6	CB 10A, 1P			1 SET
7	TERMINAL 100A, 1P			2 SETS
8	TERMINAL 60A, 1P			4 SETS
9	BUS BAR + ลูกถ้วย BUS BAR			2 SETS
10	PVC WIRE DUCT 40x40x2,000mm.			1 SET
11	C-CHANNEL			2 SETS

D. P. TRADING CO.,LTD.

1473/3 Pattannakarn 31/1, Pattannakarn Road, Suan Luang, Bangkok 10250

TEL. (02) 319 4483 FAX. (02) 318 1602-3

Draw by : D.SURACHAI	Name : ผู้ควบคุม STL ชนิดแวน แบบไม่มี TIMER 2P , 100A , 240V	Dwg No. :
Design by :	กรมทางหลวงชนบท	Scale : 1 : 10 Paper Size : A4
Approved by :		Sheet No. : 01
Date : 08/06/2566		Sheet Total : 01